

SOFT JAWS FOR PULL BACK POWER CHUCKS

バックプル式チャック用生爪

寸法図 ≫ Dimensions

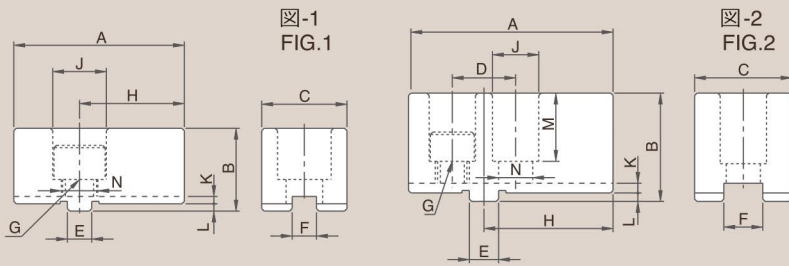

寸法表 ≫ Specifications

単位/UNIT:mm

型式 MODEL /SPEC.	A	B	C	D	E	F	G	H	J	K	L	M	N	参考図 Reference Drawing
S-06	70	34	35	--	10	10	M14x2P	43	23	3.0	3.0	21	15.5	図-1 fig.1
S-08	84	44.5	40	26	12	16	M12x1.75P	53	20	3.5	3.5	29	13.5	図-2 fig.2
S-10	100	49.5	50	32	15	18	M14x2P	62	23	3.5	3.5	32	15.5	図-2 fig.2
S-12	120	54.5	60	36	17	20	M16x2P	78	26	3.5	3.5	36	17.5	図-2 fig.2

MOUNTING PLATES

マウントプレート

- ◆ "Chadox"のマウントプレートは各種スピンドルノーズにお使い頂けます。
- ◆ "Chadox" mounting plates are available to any kinds of spindle noses.

寸法図 ≫ Dimensions

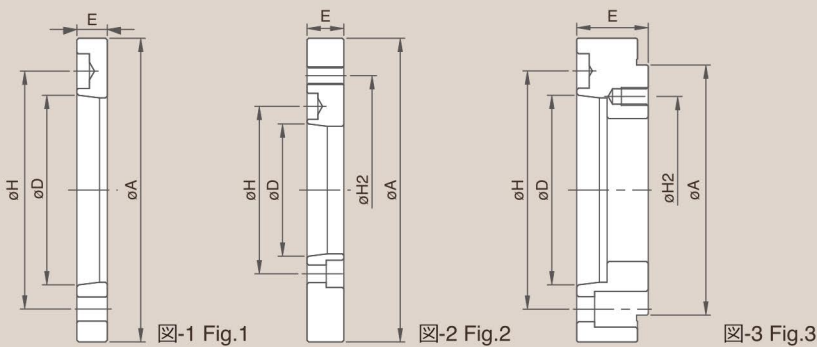

寸法表 ≫ Specifications

単位/UNIT:mm

型式 MODEL /SPEC.	スピンドルノーズ Nose of Spindle D	A	H	H2	E	参考図 Reference Drawing	型式 MODEL /SPEC.	スピンドルノーズ Nose of Spindle D	A	H	H2	E	参考図 Reference Drawing
T005A ₂ 4	A ₂ 4	110	82.6	--	20	図-1 fig.1	T004A ₂ 4	A ₂ 4	85	82.6	70.6	40	図-3 fig.3
T006A ₂ 5	A ₂ 5	140	104.8	--	15	図-1 fig.1	T005A ₂ 5	A ₂ 5	110	104.8	82.6	45	図-3 fig.3
T008A ₂ 6	A ₂ 6	170	133.4	--	17	図-1 fig.1	T006A ₂ 4	A ₂ 4	140	82.6	104.8	20	図-2 fig.2
T010A ₂ 8	A ₂ 8	220	171.4	--	18	図-1 fig.1	T006A ₂ 6	A ₂ 6	140	133.4	104.8	40	図-3 fig.3
T012A ₂ 8	A ₂ 8	220	171.4	--	18	図-1 fig.1	T008A ₂ 5	A ₂ 5	170	104.8	133.4	23	図-2 fig.2
T015A ₂ 11	A ₂ 11	300	235	--	22	図-1 fig.1	T008A ₂ 8	A ₂ 8	170	171.4	133.4	45	図-3 fig.3
T018A ₂ 11	A ₂ 11	300	235	--	22	図-1 fig.1	T010A ₂ 6	A ₂ 6	220	133.4	171.4	28	図-2 fig.2
T021A ₂ 15	A ₂ 15	380	330.2	--	27	図-1 fig.1	T012A ₂ 6	A ₂ 6	220	133.4	171.4	28	図-2 fig.2
T024A ₂ 20	A ₂ 20	520	463.6	--	27	図-1 fig.1	T012A ₂ 11	A ₂ 11	220	235	171.4	54	図-3 fig.3
T032A ₂ 15	A ₂ 15	380	330.2	--	27	図-1 fig.1	T015A ₂ 8	A ₂ 8	300	171.4	235	33	図-2 fig.2
T040A ₂ 15	A ₂ 15	380	330.2	--	27	図-1 fig.1	T018A ₂ 8	A ₂ 8	300	171.4	235	33	図-2 fig.2
							T021A ₂ 8	A ₂ 8	380	171.4	330.2	41	図-2 fig.2
							T021A ₂ 11	A ₂ 11	380	235	330.2	41	図-2 fig.2
							T024A ₂ 11	A ₂ 11	520	235	463.6	42	図-2 fig.2
							T024A ₂ 15	A ₂ 15	520	330.2	463.6	42	図-2 fig.2
							T032A ₂ 11	A ₂ 11	380	235	330.2	41	図-2 fig.2
							T040A ₂ 11	A ₂ 11	380	235	330.2	41	図-2 fig.2